

MAGLIA TONDA D20 Ø10

ROUND MESH D20 Ø10

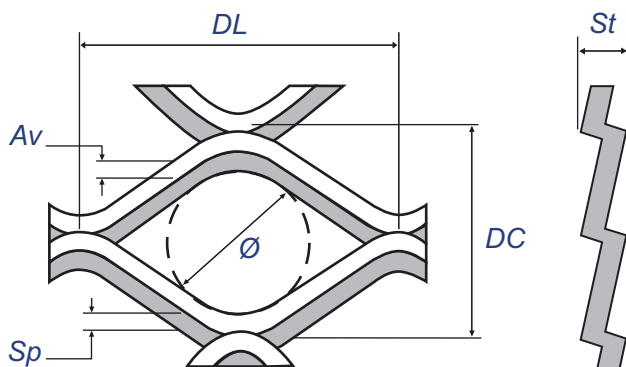

Valori espressi in mm Values in mm

DL:	Diagonale lunga	Long Way Diagonal (LWD)
DC:	Diagonale corta	Short Way Diagonal (SWD)
Av:	Avanzamento	Strand width
Sp:	Spessore	Thickness
St:	Spessore totale	Total thickness
P:	Peso al mq in kg	Weight in kg/sqm

Materiale Material	Maglia Mesh DL x DC [mm]	Avanzamento Strand [mm]	Spessore Thickness [mm]	Spessore tot. Total thickness [mm]	Formato Dimension HxL [mm]	Peso Weight [kg/mq]	Vuoto su pieno Open area in %*
Acciaio Mild steel	20 x 15	3,2	2	4,5 +/- 0,5	1000 x 2000	6,7	57%

* nominale nominal